

INJECTION MOULDING MACHINES

ROMI EN Series

NEW GENERATION

Precise.
Versatile.
Energy Efficient.



www.romi.com





MORE
PRODUCTIVITY
AND PROFITABILITY
FOR YOUR
BUSINESS!

*In the constant transformation of industrial processes, it is crucial to have **differentials that make your products superior to those offered by competitors.***

*In this context, the insertion of new technologies in its production process, mainly by means of **modern, fast and precise machines, raises production performance.***

You get higher quality, productivity, efficiency and the best: higher profits than already achieved in your business!

With more than 89 years of history and global presence, we have preserved the values that have made our products recognized worldwide. **We offer the most cost-effective injection moulding machines on the market.** Our commitment to the constant development of new solutions and dedication to innovation, results in robust, high technology and quality equipment.

We guarantee full support at all stages of purchase through our sales and sales engineering teams, customer training, specialized technical assistance and spare parts. **Having a Romi injection moulding machines assures that you have state of the art equipment** combined with a reputation of value, providing a high resale value in the future.

At Romi, you get a complete solution, much more than just equipment: **you have the security and tranquility of our full support at all times, always when you need it.** Ask us to find a suitable solution that your needs. **Our main goal is to make your business even more productive and profitable.**



Ultra Clean room

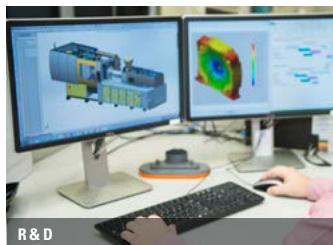

R & D



Flexible Manufacturing System (FMS)



Specialized technical assistance



Training



Spare parts

ROMI EN Series

New Generation

Energy Efficiency with Precision and Versatility.



The **ROMI EN Series**
- **New Generation** line
has been designed to provide
excellent performance, combining
high technology, productivity,
and low energy consumption.



ROMI EN 70

Clamping force	70 tonnes
Space between columns	360 x 360 mm
Opening stroke	360 mm
Injection unit	370
EUROMAP	



ROMI EN 100

Clamping force	100 tonnes
Space between columns	420 x 420 mm
Opening stroke	420 mm
Injection unit	370
EUROMAP	



ROMI EN 170

Clamping force	170 tonnes
Space between columns	550 x 550 mm
Opening stroke	500 mm
Injection unit	550, 750 e
EUROMAP	1000



ROMI EN 220

Clamping force	220 tonnes
Space between columns	620 x 620 mm
Opening stroke	560 mm
Injection unit	750, 1000 e
EUROMAP	1300



ROMI EN 300

Clamping force	300 tonnes
Space between columns	730 x 730 mm
Opening stroke	660 mm
Injection unit	1000, 1300 e
EUROMAP	2100



ROMI EN 400

Clamping force	400 tonnes
Space between columns	840 x 840 mm
Opening stroke	760 mm
Injection unit	1300, 2100 e
EUROMAP	3100



ROMI EN 500

Clamping force	500 tonnes
Space between columns	930 x 930 mm
Opening stroke	1,000 mm
Injection unit	2100, 3100,
EUROMAP	4500 e 6000



ROMI EN 650

Clamping force	650 tonnes
Space between columns	1,070 x 1,070 mm
Opening stroke	1,170 mm
Injection unit	4500, 6000 e
EUROMAP	9100

OPERATING SEGMENTS

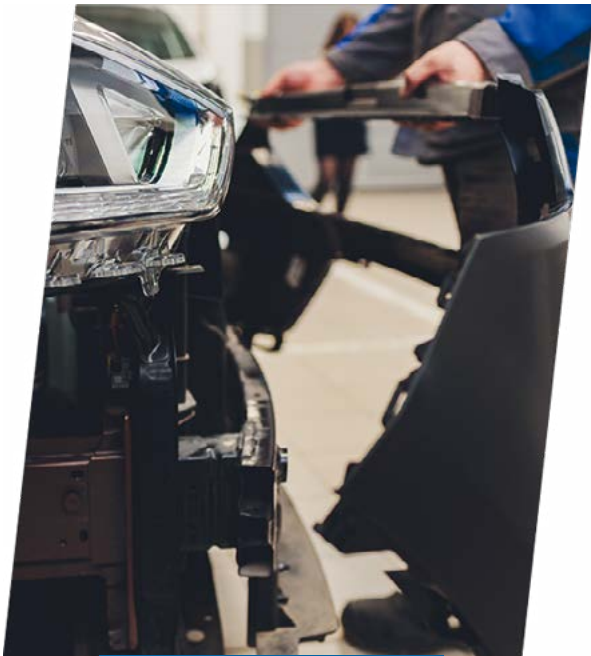

Automotive

Precision in the production of technical parts for the automotive segment.



Toys

Precision and efficiency in toy production, prepared for a wide range of applications.



Household Utilities

High-quality application of parts for use in household utilities.



Cleaning

Productivity in the production of parts for the hygiene and cleaning sector, with a mold area free from contaminants.



White Goods

Precision in the application of parts for white goods appliances.



Logistics

Excellent performance in processes that require a high injection ratio, such as pallets and transport crates.

ROMI EN Series

New Generation

Clamping Unit



- 1 Larger mould area:** the possibility to use larger moulds in line with the machine's tonnage.

Up to a **20% increase in tie-bar spacing***, allowing the use of larger moulds.

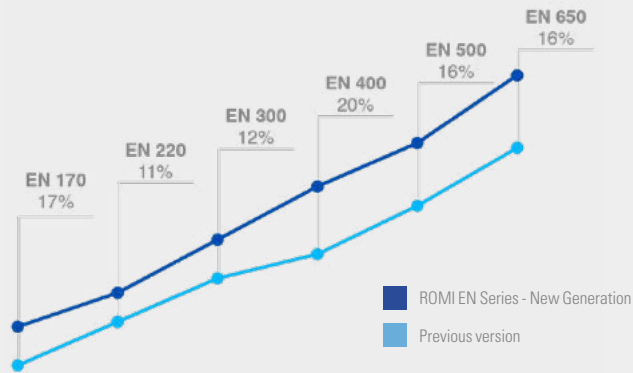

- 2 Clean and contaminant-free mould area:** the movable platen does not come into contact with the tie-bars, instead it is supported on linear guides.



- 3 Self-lubricating toggle bushings:** ensuring lower friction and smoother movements.



- 4 Hydraulic ejection with proportional valve:** improved precision and repeatability of the ejection movements.



- 5 Optimized toggle mechanism:** enables smooth movements, reduced platen deformation, and even force distribution during mould locking.



- 6 Automatic mould height and clamping force adjustment:** gear-driven actuation clamp force adjustment.



- 7 Hydraulic cores (optional):** can be installed on either the fixed or movable platen, with pressure relief.



- 8 Clean mould area due to the use of grease lubrication.**

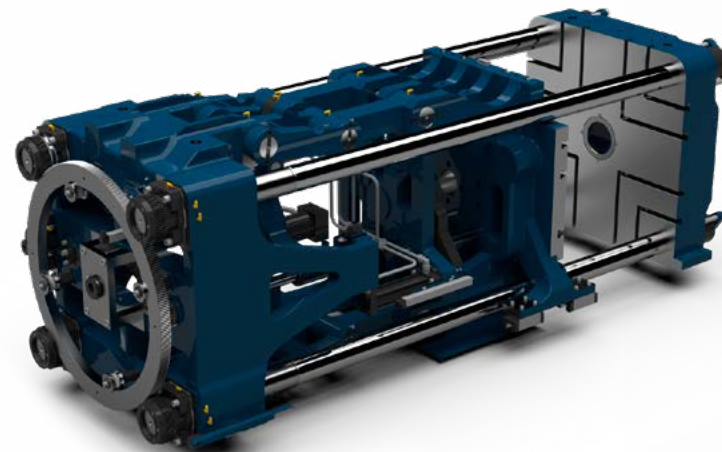

* In comparison to the previous version, not applicable to ROMI EN 70 and ROMI EN 100.





ROMI EN Series

New Generation

Injection Unit



1

Injection Unit with:

- a) Greater gram weight selection options, ensuring the best possible adaptation to the production process;
- b) Increased injection speed and higher plastification capacity, resulting in a shorter cycle time.



2

Injection Unit supported on linear guides: minimal friction during the retraction movement of the nozzle.



3

Stop and Go System: servo-pump-driven with smooth pressure-to-flow control switchover for repeatability and energy efficiency



4

High-performance and wear-resistant Plastification Assembly: ensuring high plastification performance and long service life.

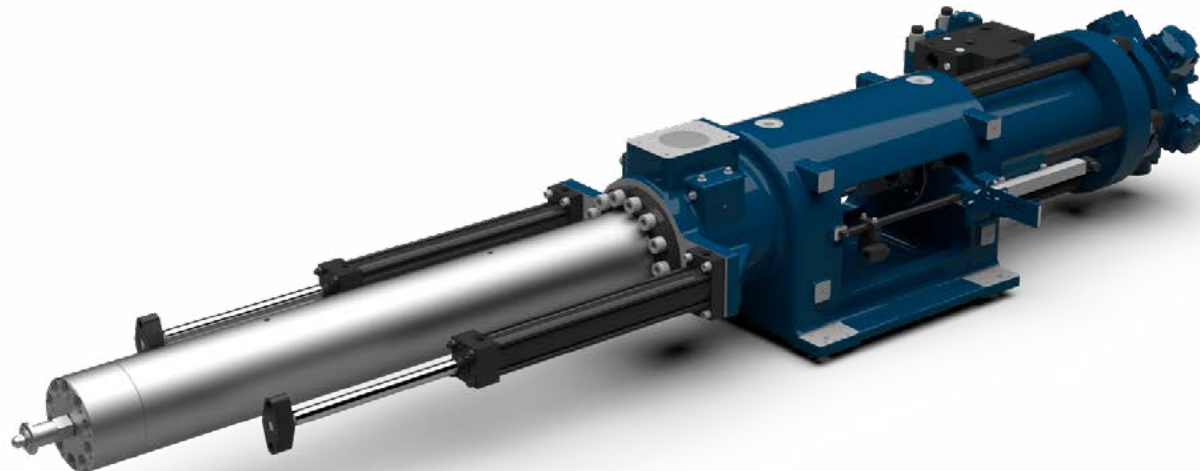

CLAMP UNIT

New dimensions of the clamping unit, designed to accommodate larger moulds that are consistent with the machine's tonnage.

5-point optimized mechanical-hydraulic bi-toggle closing system for smooth mould closing and opening movements, as well as improved force distribution during locking.

ENERGY SAVING PRINCIPLE

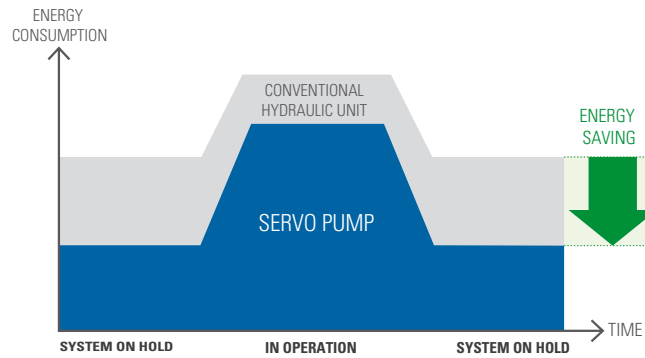

STOP AND GO

Stop and Go System: A perfect combination of servopump drive technology, high-precision hydraulics, robust mechanics, and intelligent software control.

This system ensures minimal energy consumption and extended equipment durability, along with exceptional precision in movements. Energy consumption is proportional to the demand for hydraulic pressure and speed in movements.

ENERGY SAVING

The hydraulic system of the ROMI EN Series - New Generation machines ensures minimal energy consumption thanks to the flow and pressure control loop being directly integrated into the servopump drive. Energy consumption is close to zero during static phases of the process (cooling and part ejection). Excellent precision and repeatability result in an exceptionally low standard deviation of part weight, potentially leading to material cost savings of up to 2.5%.

Energy consumption - Conventional machine x Servo pump

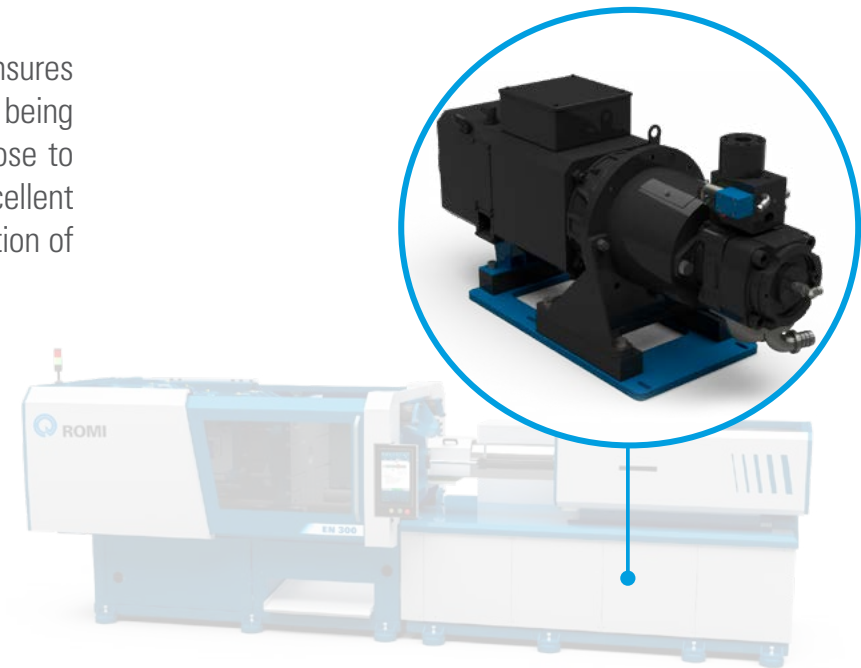
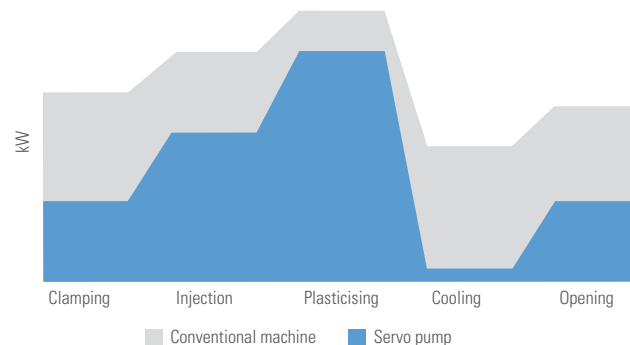



PLASTICIZING SET

The plasticizing assembly of the ROMI EN Series - New Generation machines uses bimetallic-coated plasticizing screws, providing increased wear resistance and ensuring a long service life when processing thermoplastic materials with fillers and recycled materials.

A wide range of plasticizing assembly options for the best fit to the production process.



VERSIONS FOR THERMOSET, PVC, AND PET

Technology, Productivity, and Efficiency in the Production of Thermoset, PVC, and PET Bottle Preforms.

MULTICOMPONENT LINE

Developed specifically for the injection of multi-component and multi-colour parts.

Examples of injector unit configurations:

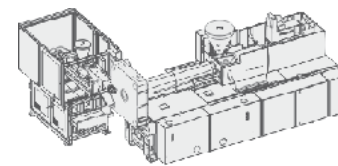

Side mounted

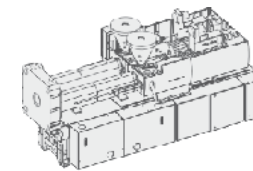

Double parallel

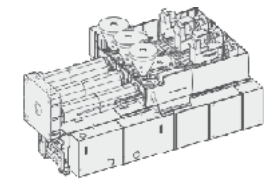

Treble parallel

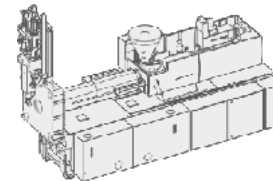

Vertical

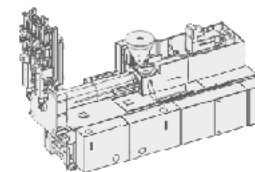

Double vertical plus main horizontal

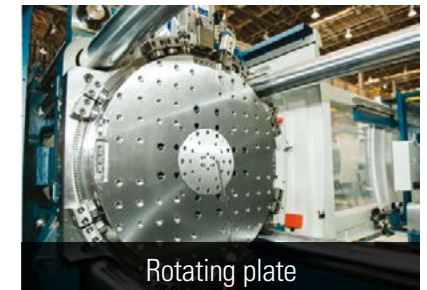

Rotating plate

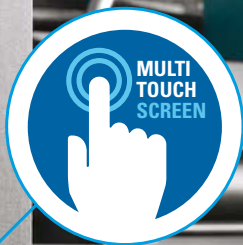

CM20 PLUS CONTROL

NEW GENERATION

- Full HD 19" Touchscreen Display
- 2.2 GHz Dual-Core Processor
- 8GB RAM Memory
- 32GB C-FAST Storage
- USB and TCP/IP Interface Ports
- Peripheral Connectivity
- Statistical Process Control
- Production Control
- Integration with MES Systems
- Remote Maintenance and Support (Optional)
- Viewing via Mobile Devices (Webserver/VNC)
- Easy and Intuitive Programming
- Multi User level access control

MMI FEATURES

New navigation system:
Machine and process variables visible on all pages

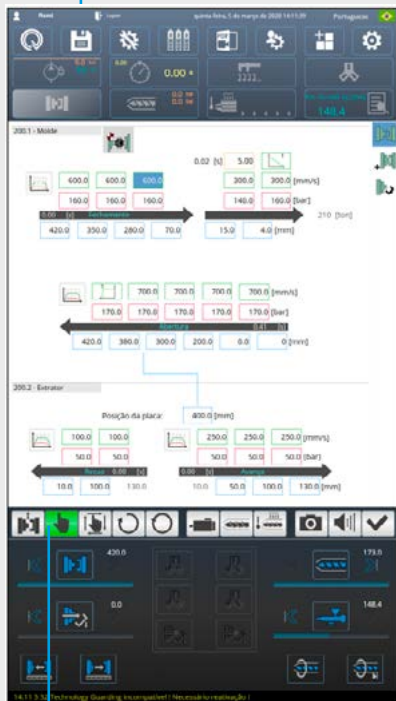

New Manual Axis Control Mode - Multi-Touch



Automatic Mould Protection:
Increased Sensitivity



Automatic Screw Rotation Adjustment: Improved Performance and Reduced Energy Consumption

INTELLIGENT INJECTION CONTROL

This Machine Learning feature adds adaptive injection control, simplifying adjustments and enhancing process stability, reducing up to 3 times the variation in the weight of injected parts by up to up to 3 times.



PERIPHERAL INTEGRATION

Mirroring the graphical interface of devices via VNC.

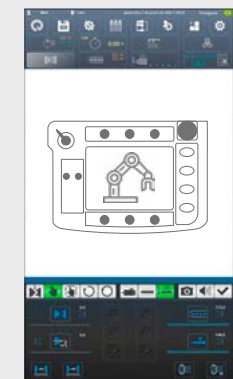
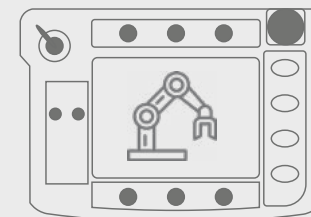

Technical Specifications		ROMI EN 70	ROMI EN 100	ROMI EN 170	ROMI EN 220	ROMI EN 300	ROMI EN 400	ROMI EN 500	ROMI EN 650
--------------------------	--	------------	-------------	-------------	-------------	-------------	-------------	-------------	-------------

CLAMPING UNIT

Mould clamping force	t	70	100	170	220	300	400	500	650
Maximum opening stroke	mm	360	420	500	560	660	760	1.000	1.170
Mould height (maximum x minimum)	mm	360 - 130	460 - 160	550 - 220	650 - 260	750 - 300	840 - 340	1,000 - 370	1,170 x 400
Minimum mould size (square)	mm	265 x 265	300 x 300	345 x 345	415 x 415	480 x 480	520 x 520	590 x 590	650 x 650
Maximum mould size	mm	540 x 360	640 x 420	780 x 550	890 x 620	1,040 x 730	1,200 x 840	1,350 x 930	1.560 x 1.070
Plates size (horizontal x vertical)	mm	540 x 540	640 x 640	780 x 780	890 x 890	1,040 x 1,040	1,200 x 1,200	1,350 x 1,350	1.560 x 1.560
Space between columns (horiz. x vert.)	mm	360 x 360	420 x 420	550 x 550	620 x 620	730 x 730	840 x 840	930 x 930	1.070 x 1.070
Maximum opening stroke	mm	720	880	1,050	1,210	1,410	1,600	2,000	2,340
Hydraulic Ejector	Ejection force	t	3.5	3.5	7.1	7.1	11.2	11.2	11.2
	Stroke	mm	100	130	180	180	250	250	320

Machine Dimensions

FRONT VIEW

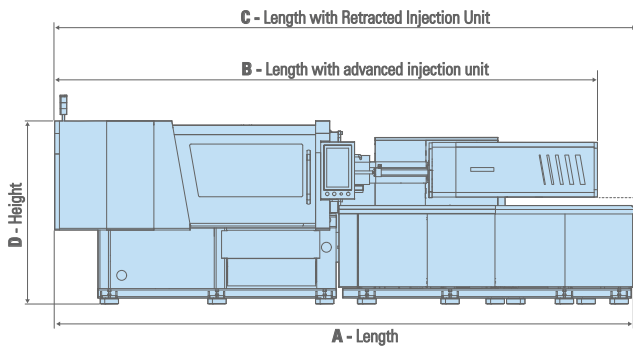

SIDE VIEW

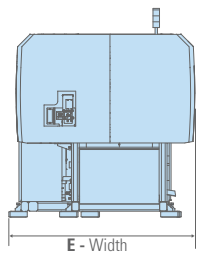

		EN 70	EN 100	EN 170			EN 220			EN 300			EN 400			EN 500			EN 650			
EUROMAP	tipo	370	370	550	750	1000	750	1000	1300	1000	1300	2100	1300	2100	3100	2100	3100	4500	6000	4500	6000	9100
A - Length	m	4.25	4.60	5.25	5.75	5.95	5.95	6.15	6.30	6.60	6.70	6.70	7.20	7.20	7.95	8.50	9.20	9.90	10.30	10.55	11.00	11.00
B - Length with advanced injection unit	m	4.20	4.40	4.90	5.30	5.30	5.55	5.75	5.90	6.15	6.30	6.75	6.70	7.20	7.65	8.53	8.83	9.30	10.40	9.97	11.20	11.40
C - Length with Retracted Injection Unit	m	4.50	4.73	5.25	5.75	6.00	6.00	6.20	6.30	6.60	6.75	7.30	7.20	7.75	8.20	9.00	9.50	9.90	11.00	10.60	11.70	12.10
D - Height	m	1.80	1.90	1.90			1.95			2.10			2.25			2.40			2.50			
E - Width	m	1.50	1.50	1.70			2.00			2.10			2.20			2.47			2.75			
Weight	t	3.7	5.1	7.1	7.6	8.5	8.7	9	9.4	12.95	14.55	15	13	14	15	29	30.5	32	33	34.7	36.7	38.2

EUROMAP Classification		370	550	750	1000	1300	2100	3100	4500	6000	9100
------------------------	--	-----	-----	-----	------	------	------	------	------	------	------

INJECTION UNIT

Screw Diameter	mm	35	40	45	40	45	50	45	50	55	50	55	60	55	60	70	60	70	80	70	80	90	80	90	100	90	100	115	100	115	125
Screw Ratio	L/D	22.0	20.0	18.0	22.5	20.0	18.0	22.2	20.0	18.2	22.0	20.0	18.3	21.8	20.0	17.1	23.3	20.0	17.5	22.9	20.0	17.8	22.5	20.0	18.0	22.2	20.0	17.4	23.0	20.0	18.4
Maximum Injection Volume	cm ³	173	226	286	226	286	353	318	393	475	432	523	622	570	679	924	792	1,078	1,407	1,232	1,608	2,036	1,810	2,290	2,827	2,417	2,985	3,947	3,613	4,778	5,645
Maximum Injection Weight (PS)	g ⁽¹⁾	163	213	269	215	270	335	300	370	450	410	490	585	540	640	870	745	1,015	1,325	1,160	1,515	1,915	1,700	2,160	2,660	2,300	2,800	3,700	3,400	4,500	5,300
Maximum Injection Pressure	bar ⁽²⁾	2,100	1,600	1,300	2,400	1,900	1,530	2,350	1,900	1,560	2,310	1,910	1,600	2,250	1,900	1,400	2,450	1,900	1,450	2,350	1,900	1,500	2,400	1,960	1,600	2,300	2,000	1,500	2,350	1,900	1,600
Injection Rate	cm ³ /s ⁽²⁾	140	180	230	160	200	250	210	260	315	255	310	370	320	380	520	335	460	600	450	590	745	530	670	830	680	840	1,110	840	1,110	1,300
Injection Speed	mm/s ⁽²⁾	146	143	145	127	126	127	132	132	133	130	130	131	135	134	135	118	120	119	117	117	117	105	105	106	107	107	107	107	107	106
Plastification Rate	g/s ⁽³⁾	16	24	34	21	30	41	27	38	50	34	46	60	41	53	85	46	73	110	63	94	134	84	120	165	110	150	230	136	206	265
Maximum Screw Speed	rpm ⁽³⁾	385rpm @ 40kgf.m			340rpm @ 53kgf.m			310rpm @ 70kgf.m			280rpm @ 90kgf.m			255rpm @ 120kgf.m			220rpm @ 180kgf.m			190rpm @ 250kgf.m			170rpm @ 340kgf.m			155rpm @ 470kgf.m			140rpm @ 650kgf.m		
Maximum Screw Torque	kgf.m	67kgf.m @ 230rpm			86kgf.m @ 210rpm			114kgf.m @ 190rpm			147kgf.m @ 170rpm			187kgf.m @ 165rpm			286kgf.m @ 140rpm			410kgf.m @ 120rpm			520kgf.m @ 110rpm			710kgf.m @ 100rpm			940kgf.m @ 90rpm		
Maximum Nozzle Diameter	mm ⁽⁴⁾	21	24	27	27	26	27	32	32	33	30	30	31	24	27	31	23	27	30	30	34	38	29	33	38	29	33	38	29	33	36
Oil Reservoir Volume	l	280			280			400			400			600			600			740			440 + 440			675 + 675			675 + 675		

ELECTRICAL DATA

Main Motor (Servo Motor)	kW	25			25			36			36			64			64			64			43 + 43			64 + 64			64 + 64		
Heating Power	kW	10			13.1			14.4			16.5			20.9			28.5			37.8			48.4			58.6			77.4		

	Dry Cycle - EUROMAP 6 (seconds)										
	370	550	750	1.000	1.300	2.100	3.100	4.500	6.000	9.100	
ROMI EN 70	1,4										
ROMI EN 100	1,7										
ROMI EN 170		2,2	2	1,8							
ROMI EN 220			2,3	2,1	2,1						
ROMI EN 300				2,5	2,3	2,3					
ROMI EN 400					2,8	2,6	2,6				
ROMI EN 500						3,2	3,0	2,8	2,8		
ROMI EN 650								3,2	3,0	3,0	

	EUROMAPS - Injection unit options										
	370	550	750	1000	1300	2100	3100	4500	6000	9100	
ROMI EN 70	●										
ROMI EN 100	●										
ROMI EN 170		●	●	●							
ROMI EN 220			●	●	●						
ROMI EN 300				●	●	●					
ROMI EN 400					●	●	●				
ROMI EN 500						●	●	●	●		
ROMI EN 650								●	●	●	

⁽¹⁾ Approximate Values.

⁽²⁾ Instantaneous values and cannot be guaranteed when using maximum injection pressure.

⁽³⁾ Estimated values with Polystyrene (PS) material at a temperature of 220°C to 250°C and maximum screw speed.

⁽⁴⁾ Maximum diameter of the nozzle's projected area.

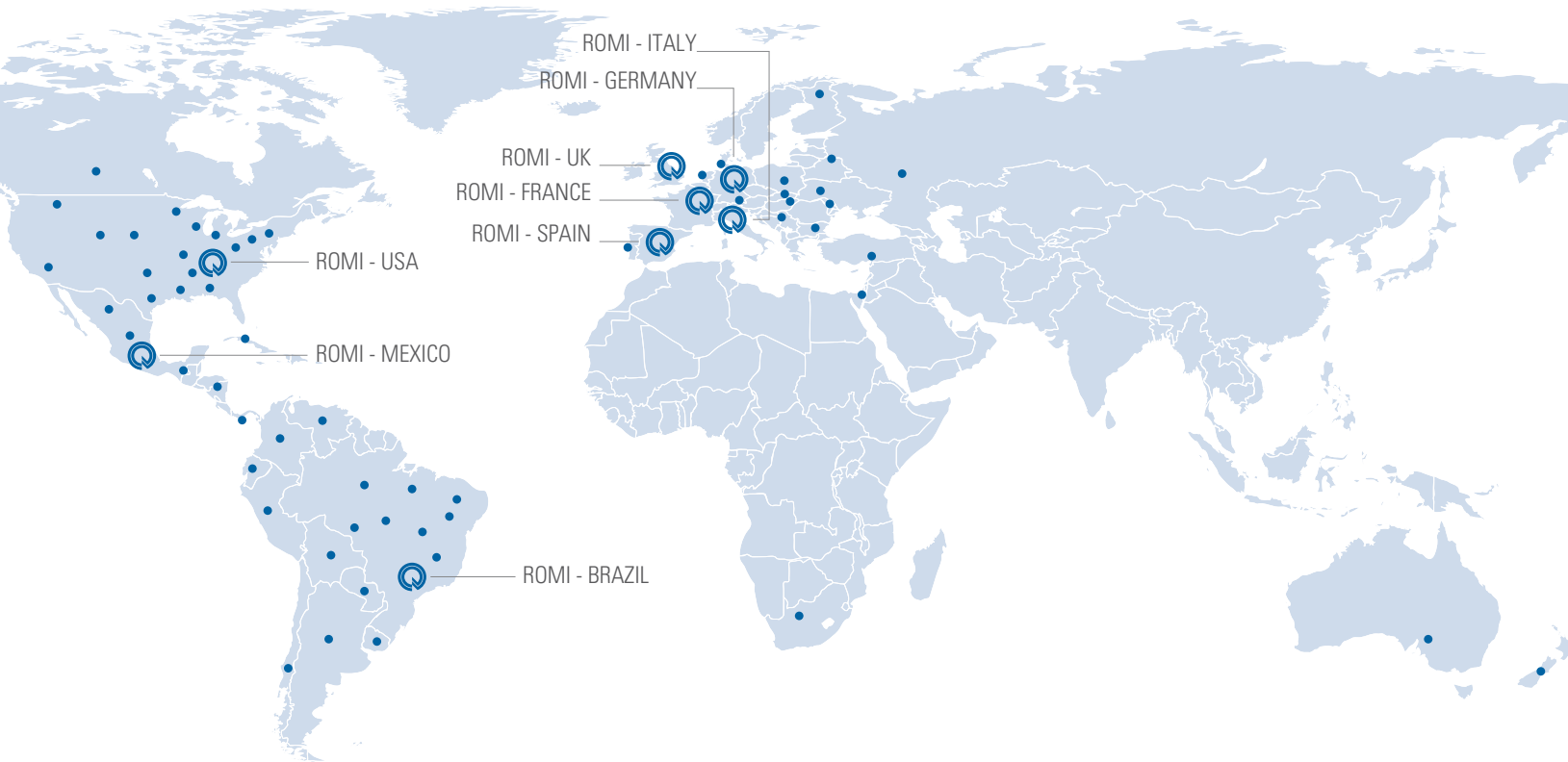

ROMI

WWW.ROMI.COM

ROMI S.A.

Rod. SP 304, km 141,5
Santa Bárbara d'Oeste/SP
13459-057 - Brasil
(19) 3455 9735
maqfer@romi.com

ROMI América Latina

(19) 3455 9642
export-mf@romi.com

**Burkhardt+Weber
Fertigungssysteme GmbH**

Tel +49 7121 315-0
info@burkhardt-weber.de
www.burkhardt-weber.de

**ROMI BW Machine
Tools, Ltd**

Tel +1 (859) 647 7566
sales-usa@romi.com
www.romiusa.com

ROMI Europa GmbH

Tel +49 7121 315-604
sales@romi-europa.de
www.romi-europa.de

ROMI France SAS

Tel +33 4 37 25 60 70
infos@romifrance.fr
www.romifrance.fr

**ROMI Machines
UK Limited**

Tel +44 1788 544221
sales@romiuk.com
www.romiuk.com

**ROMI Maquinas
España**

Tel +34 93 719 4926
info@romi.es
www.romi.es

ROMI en México

Tel +521 55 9154 5851
ventasmx@romi.com
www.romimexico.com

ROMI Itália Srl

Tel +39 0523 778 956
commerciale@romitalia.it
www.romitalia.it



Brazil



Spain



United States



Italy



Germany



Mexico



UK



France



Germany - BW

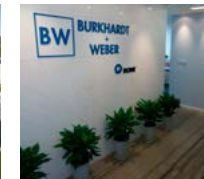

China - BW



ISO 9001:2015
Certificate No. 31120



ISO 14001:2015
Certificate No. 70671

CE safety regulation compliance available only for the European Community or under request.
Check availability and technical characteristics of the products to your country.